

Tyro Musca / Aquarius, Sedna / Aquarius

Datasheet 868 MHz



The basic frequency of our remote control sets is 868 MHz. This frequency is only used by professionals, this means that interference from other systems will be close to none.

System communication specifications

Frequency	868 MHz (Multiple frequencies possible)
Communication / modulation	FM
Transmission power	< 10 mW
RF sensitivity	-115 dB
Reaction time after pressing a button	< 100 ms
I.D. code	24-bit
Channel distance / hamming distance	200 kHz
Range under normal circumstances	350 meters
Range under normal circumstances incl. RF amplifier	700 meters
Emergency button on transmitter	Complies to CE requirements
Temperature resistance	-30°C / 75°C
Number of transmitters per receiver	Standard up to 54



Tyro Musca / Aquarius, Sedna / Aquarius

Datasheet 868 MHz

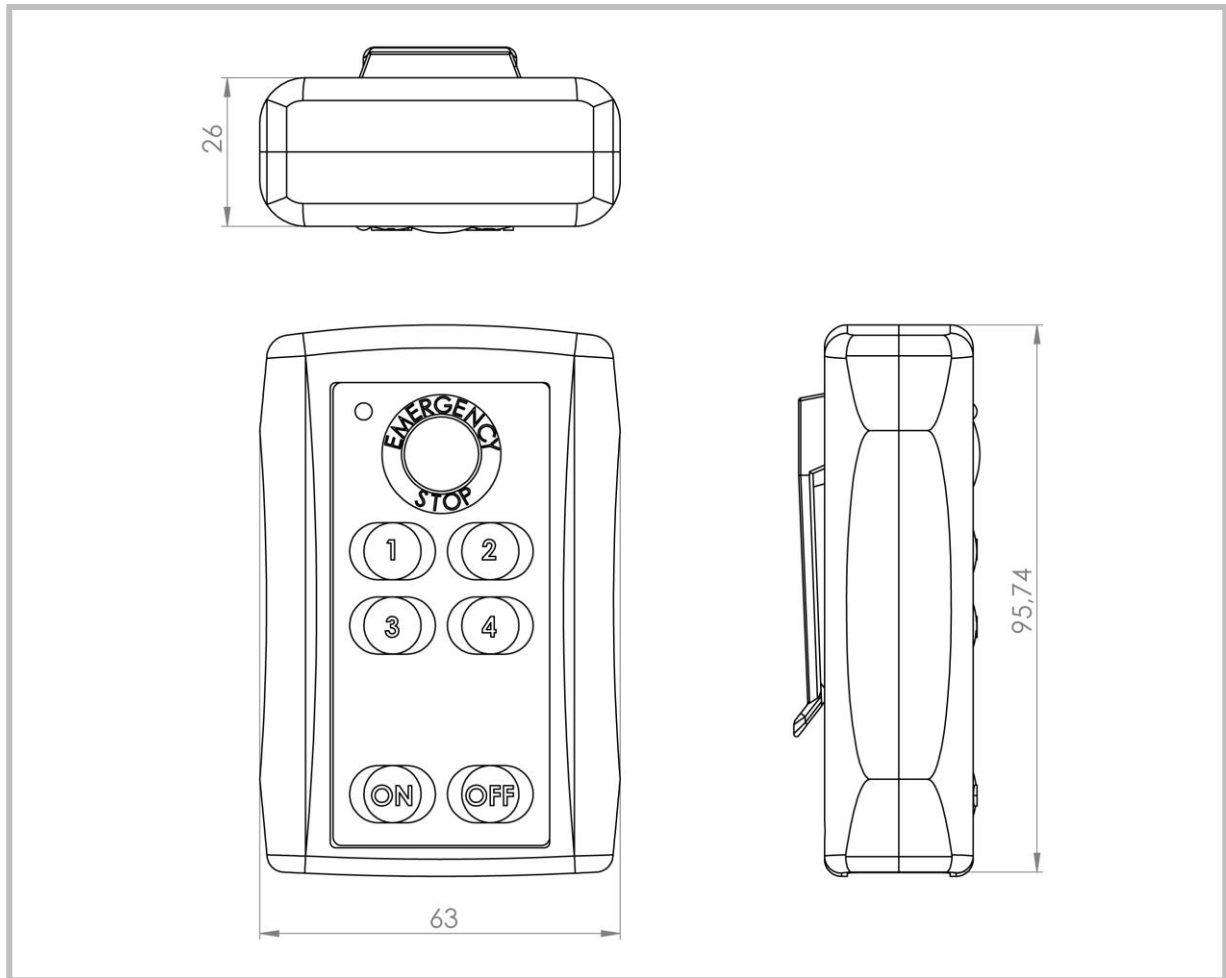

Transmitter power supply

Powersupply	1x 9V block
Service time	+/- 2 years under normal circumstances
Power withdrawal	3.5 mA

Transmitter buttons

Number of function keys	2 or 4
Emergency button	Present

Transmitter enclosure

Weigth	192 gr
Resistance to damp and dirt	IP 65
Material	ABS (Impact-resistant / 2 meters fall guaranteed)

Tyro Musca / Aquarius, Sedna / Aquarius

Datasheet 868 MHz

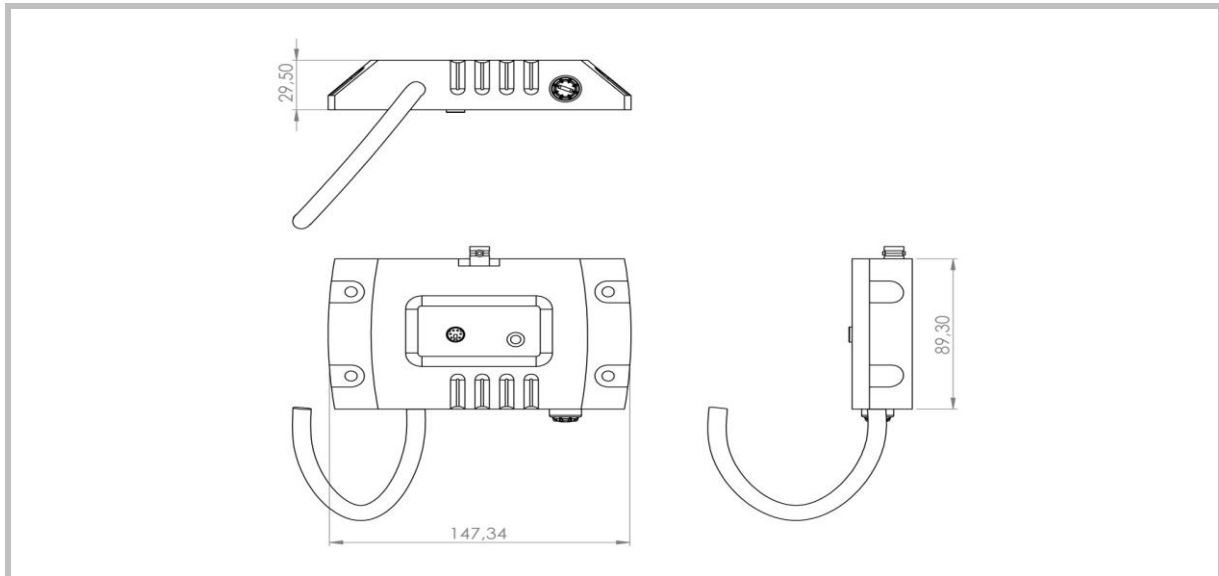

Receiver enclosure

Weight	480 gr
Resistance to damp and dirt	IP 68 (100% waterproof)
Material	Polyurethane (impact-resistant / mutes vibrations)

Receiver configuration

Power	8-38 Vdc (various voltages possible)
Number of switching units	Max 6
Type of switching unit	MosFet
Fuse	10 Amp fast-glass fuse integrated 5 x 20 mm
Short circuit protection	Present on every output
Max. Load	4A (Larger currents are possible)

Digital inputs

Number of digital inputs	1
Max. Load	38V
Low detection	< 4V
High detection	> 6V

PWM output

Number of PWM outputs	2
Max. Frequency	2 KHz

Safety

Max. safety category	Category 3 EN 954-1/ISO 13849-1
----------------------	---------------------------------

Optional functions

Two-hand control	Multiple key-combinations possible
Key hold down function	Possible on every output
Power save mode	Possible with various intervals
Other supply voltages	Possible
Other switching voltages	Possible

After consideration other options can also be realized!